



Chassis Technical Bulletin CTB 011, 15 July 2009

Title: Mud Flaps

Component: Mud Flaps

Condition: Cut or torn mud flap and proper length.

Action Required: Replace

Note:

When replacing mud flaps, the distance/clearance from the bottom edge of the replaced flap to the ground is critical.

While presently there are no US Government guidelines, some States may have ground to mud flap bottom edge clearance distance rules. Where States have no rules, there are two Industry recommendations on mud flap ground clearance:

SAE (Society of Automotive Engineers)

This is frequently called the “SAE 22.5 degree rule”. The bottom edge of the mud flap should be above the ground by no more than a line which projects upward at a 22.5 degree angle from the intersection of the vertical centerline of the rearmost tire w/ the ground.

As examples:

- If the DISTANCE from forward face of the mud flap to the center of the axle is 24”, then the bottom edge of the flap to GROUND CLEARANCE will be 10”.
- If the DISTANCE from forward face of the mud flap to the center of the axle is 30”, then the bottom edge of the flap to GROUND CLEARANCE will be 12.5”.



Diagram of “SAE 22.5 Degree Rule” Recommendation:

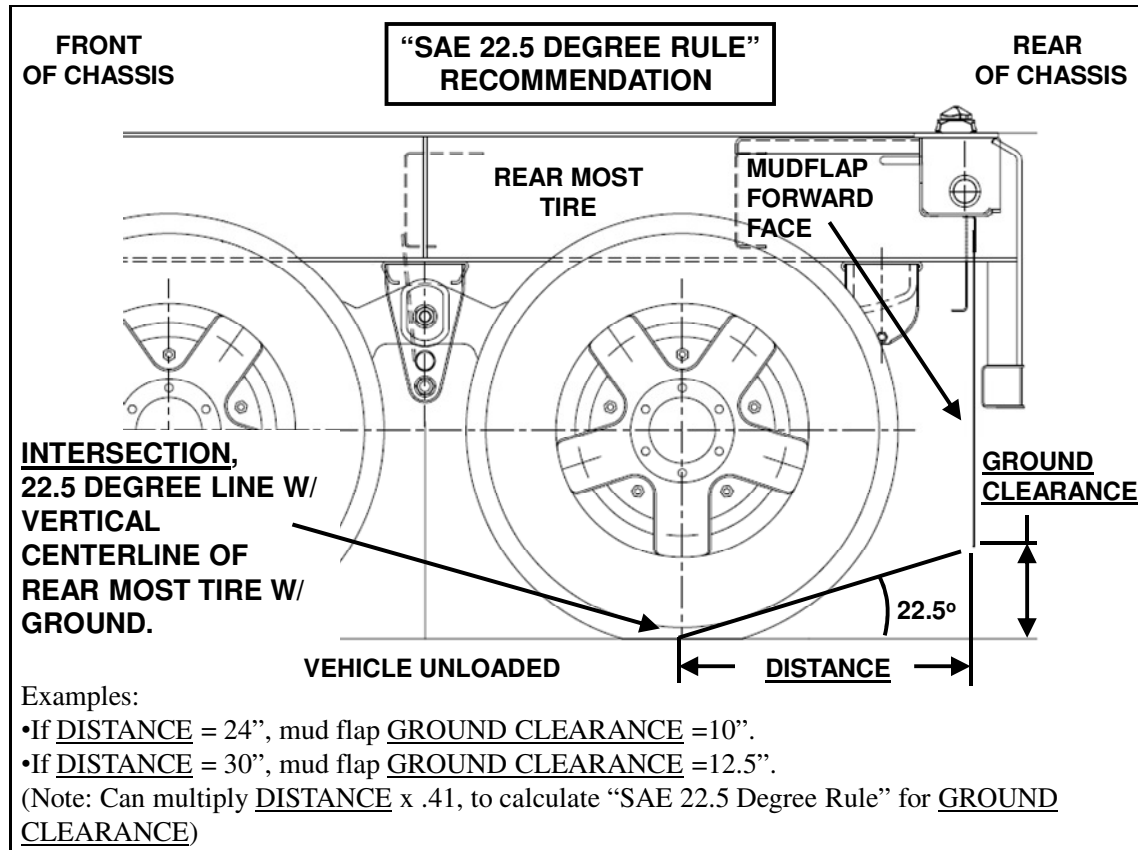

NTEA (National Truck Equipment Association)

The bottom edge of the mud flap should be above the ground by no more than 1/3 of the distance from the intersection of the vertical centerline of the rearmost tire w/ the ground to the location where the mud flap will hang (distance is from vertical centerline of the rearmost tire to the forward face of the mud flap).

As examples:

- If the DISTANCE from forward face of the mud flap to the center of the axle is 24”, then the bottom edge of the forward face of flap to GROUND CLEARANCE will be 8”.
- If the DISTANCE from forward face of the mud flap to the center of the axle is 30”, then the bottom edge of the flap to GROUND CLEARANCE will be 10”.



Diagram of NTEA Recommendation:

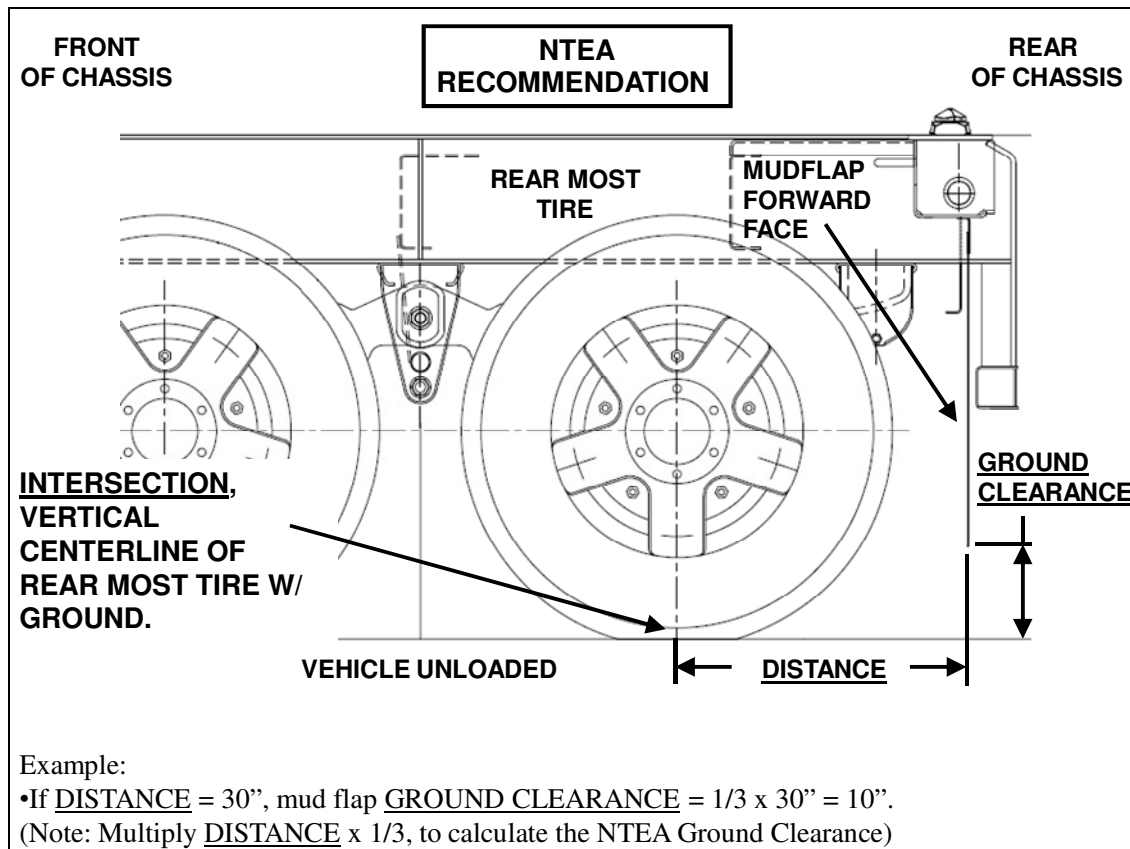

It should be noted that the NTEA recommendation locates the bottom edge of the flap closer to the ground. In lieu of any State rule which requires still less distance, this may be preferred by owners/operators.

However, in ALL cases, the owner/operator must insure compliance to the mud flap ground clearance needs of the States in which the chassis is to be operated.