



## IICL Chassis Technical Bulletin – CTB 021, February 12, 2015

### **Title: Best Practices – Removal and Installation of Wheel Assembly (Tire Mounted to Rim Assembly) From Container Chassis**

This document does **NOT** address de-mounting and mounting of tires on rims and disc wheels.

These procedures are to be followed by workers trained and instructed in correct procedures. **Tire vendor is responsible to comply with all OSHA and local regulations regarding safe work practices and other referenced experts on key aspects of wheel assembly removal and reinstallation.** Handle tires with respect and don't take shortcuts. For additional information on safety practices and technical data, refer to latest copy of *Section RP222B, User's Guide to Wheels & Rims*, within the ATA / TMC "Intermodal Recommended Practices Manual".

**An inflated tire contains explosive energy. The sudden release of this energy by a tire blowout, rim / ring separation, and/or rim wedge clamp blowout can cause serious injury or death. Never stand directly in front of an inflated tire. The trajectory of exploding parts is usually but not always perpendicular to the sidewall of the tire. **Therefore, before loosening any nuts or clamps that attach a wheel assembly to a vehicle, ALWAYS completely deflate the tire (or BOTH tires of a dual assembly) by taking out the valve core(s)****

**For OSHA information, consult:**

<https://www.osha.gov/Publications/wheel/wheel-chart-booklet.pdf>

## **CONTENTS**

1.0	Removal of MULTI PIECE RIMS from SPOKE WHEELS on chassis .....	3
2.0	Removal of SINGLE PIECE RIMS from SPOKE WHEELS on chassis .....	4
3.0	Re-Installation of either MULTI PIECE or SINGLE PIECE RIMS onto SPOKE WHEELS on chassis.....	5
4.0	Removal of HUB PILOTED DISC WHEEL RIMS from chassis .....	6
5.0	Re-Installation of HUB PILOTED DISC WHEEL RIMS onto chassis.....	7

## 1.0 **Removal of MULTI PIECE RIMS from SPOKE WHEELS on chassis**

- 1.1 Always be aware of the position, condition, and fit of side rings on multi-piece (10.00 X 20 tube-type) rims. Visually inspect tires and rims; Cracks, severe corrosion or obvious poor fit should be rejected. Corrosion (rims, wheels, studs, nuts, clamps) that clearly will affect structural integrity should be repaired / replaced.
- 1.2 Chock wheels; Jack vehicle; use axle stands if available.
- 1.3 Check the air pressure of both tires of a dual assembly with a pressure gage. Mark tire pressures on tire sidewalls.
- 1.4 **BOTH** tires of a dual wheel assembly must be completely deflated **BEFORE** loosening nuts for removal from the axle.
- 1.5 When deflating any tire, stand to the side; use a valve stem 'wrench' to remove valve core and deflate tire.
  - 1.5.1 Run a piece of wire into the valve stem to be sure there are no obstructions to deflation and that deflation is complete.
- 1.6 **AFTER BOTH TIRES ARE COMPLETELY DEFLATED**, begin to break lug nuts loose with a few turns of a socket wrench in a "star" or "crisscross" pattern (see Figure 1 for spoke wheel lug nut patterns).
  - 1.6.1 Do not remove lug nuts at this time; only loosen with a few turns.
- 1.7 Rim clamps work by "wedging" the rim; be sure all clamps are free before completely removing lug nuts.
  - 1.7.1 If a clamp is still wedged, gently tap it with a rubber mallet while lug nuts are still loosely attached;  
**WARNING: DO NOT USE HARD SURFACE HAMMERS.**
  - 1.7.2 Remove all lug nuts.
- 1.8 Carefully remove the rim(s) taking care not to damage stud threads.
  - 1.8.1 Wipe mounting surfaces of rim to remove dirt and corrosion; use wire brush if needed; mounting surfaces should be smooth and clean.

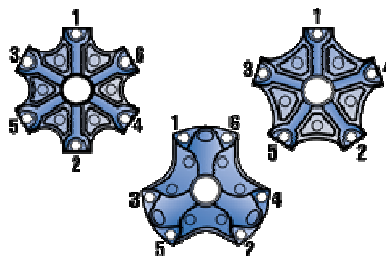

Figure 1: Six (6), five (5), and three (3) spoke wheels

## 2.0 **Removal of SINGLE PIECE RIMS from SPOKE WHEELS on chassis**

- 2.1 Visually inspect tires and rims; Cracks, severe corrosion or obvious poor fit should be rejected. Corrosion (rims, wheels, studs, nuts, clamps) that clearly will affect structural integrity should be repaired / replaced.
- 2.2 Chock wheels; Jack vehicle; use axle stands if available
- 2.3 Check the air pressure of both tires of a dual assembly with a pressure gage. Mark tire pressures on tire sidewalls.
- 2.4 **BOTH** tires of a dual wheel assembly must be completely deflated **BEFORE** loosening nuts for removal from the axle.
- 2.5 When deflating any tire, stand to the side; use a valve stem 'wrench' to remove valve core and deflate tire.
  - 2.5.1 Run a piece of wire into the valve stem to be sure there are no obstructions to deflation and that deflation is complete.
- 2.6 **AFTER BOTH TIRES ARE COMPLETELY DEFLATED**, begin to break lug nuts loose with a few turns of a socket wrench in a "star" or "crisscross" pattern (see Figure 1 for spoke wheel lug nut patterns).
  - 2.6.1 Do not remove lug nuts at this time; only loosen with a few turns.
- 2.7 Rim clamps work by "wedging" the rim; be sure all clamps are free before completely removing lug nuts.
  - 2.7.1 If a clamp is still wedged, gently tap it with a rubber mallet while lug nuts are still loosely attached;  
**WARNING: DO NOT USE HARD SURFACE HAMMERS.**
  - 2.7.2 Remove all lug nuts.
- 2.8 Carefully remove the rim(s) taking care not to damage stud threads.
  - 2.8.1 Wipe mounting surfaces of rim to remove dirt and corrosion; use wire brush if needed; mounting surfaces should be smooth and clean.

### 3.0 **Re-Installation of either MULTI PIECE or SINGLE PIECE RIMS onto SPOKE WHEELS on chassis**

- 3.1 Carefully position re-assembled rim and tire on the spoke wheel hub taking care not to damage stud threads.
  - 3.1.1 For the inner rim: be sure to push the rim fully back on the rim mounting surface of the spoke wheel hub, and ensure that the valve is centered between two spokes and pointing out.
  - 3.1.2 After placing the inner rim, carefully push the spacer into place, against inner rim. Do not tilt the spacer or rim.
  - 3.1.3 After pushing spacer into place against inner rim, carefully push the outer rim against the spacer. Do not tilt the spacer or rim.

Note: Both air valves should be in the middle of two spokes; inner tire valve facing out, outer tire valve facing in; Best practice is to have the inner and outer air valves centered between opposite spokes.

- 3.1.4 Position clamps over studs to achieve full mounting surface against outer rim.
- 3.1.5 Hand-tighten lug nuts in a crisscross or star pattern (see Figure 1).
- 3.1.6 As nuts become snug, use a manual socket wrench (no air wrenches – incremental tightening is important for proper installation). Tighten each nut ½ turn in a crisscross or star pattern. This technique is important to properly mount and balance the rim against the spokes and to prevent “wobbling.”
  - 3.1.6.1 The same number of threads should show above the lug nut after each tightening sequence – this is just a visual check for equal tightening.
- 3.1.7 **CRITICAL**: Check that the wheel assembly runs “true”/rotates in a straight path by placing a block of wood on the ground almost touching the tire and rotating the tire; Note how far the tire comes to or from the block (“run-out”); a variation of more than 1/16” means that tightening / loosening clamps might be needed to true the wheel assembly and stop wobbling.
- 3.2 When the wheel assembly is true with no wobble, use a calibrated manual torque wrench and tighten/torque ¾” lug nuts in the crisscross or star pattern to 200-260 lb.-ft. dry (no oil). Do not over torque – it damages studs.
- 3.3 Be sure both tires have sealing flow-through valve caps, or other type, as specified by owner.

#### 4.0 **Removal of HUB PILOTED DISC WHEEL RIMS from chassis**

- 4.1 Chock wheels; Jack vehicle; use axle stands if available.
- 4.2 Visually inspect tires and rims; Cracks, severe corrosion or obvious poor fit should be rejected. Corrosion (rims, wheels, studs, nuts) that clearly will affect structural integrity should be repaired / replaced. Wheels with stud holes that are elongated (not round) or that are not covered by the lug nut 'washer' should be replaced.
- 4.3 **BOTH** tires of a dual wheel assembly must be completely deflated **BEFORE** loosening nuts for removal from the axle.
- 4.4 When deflating any tire, stand to the side; use a valve stem 'wrench' to remove valve core and deflate tire.
  - 4.4.1 Run a piece of wire into the valve stem to be sure there are no obstructions to deflation and that deflation is complete.
- 4.5 **AFTER BOTH TIRES ARE COMPLETELY DEFLATED**, begin to break lug nuts loose with a few turns of a socket wrench in a "star" or "crisscross" pattern (see Figure 2 for hub-piloted disc wheel lug nut patterns). Air wrench may be used to loosen.
  - 4.5.1 Remove lug nuts in a crisscross or star pattern.
- 4.6 Carefully remove wheel from hub/drum taking care not to damage studs.
  - 4.6.1 Check wheel for cracks, excessive corrosion, distortion, elongated stud holes.

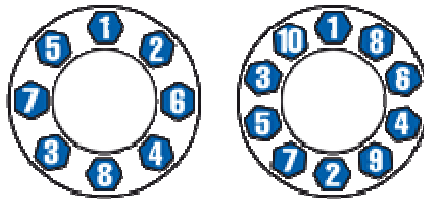

Figure 2: Eight (8) and ten (10) lug hub-piloted disc wheels

## 5.0 **Re-Installation of HUB PILOTED DISC WHEEL RIMS onto chassis**

- 5.1 Clean hub/drum and wheel mating surfaces and check that all mating surfaces are flat.
- 5.2 Presuming chassis was originally equipped with **HUB-PILOTED** wheels, be sure to use hub-piloted wheels on the hub-piloted hubs;
  - 5.2.1 Lug holes on hub-piloted wheels are not chamfered, and lug nuts have integral/rotating flanges at their back end.
  - 5.2.2 **As information**, lug holes on **stud** piloted disc wheels often have chamfered holes, and require inner and outer ball-seated lug nuts.

Wheel mounting steps for chassis originally equipped with **HUB-PILOTED** disc wheels:





- 5.3 Lightly lubricate the flat surface of the hub pilot; lightly lubricate (drop of oil) between each lug nut and its flange. Insure that flange washer is NOT seized to the nut. **Per TMC – Oil (*one or two drops*) the last 2-3 threads.**
- 5.4 Slide the wheel(s) over the hub taking care not to damage the studs.
- 5.5 Align handholds of the duals to allow access to tire valves; Valves should be opposite to each other or as close to opposite as possible, and accessible to inflation hose.
- 5.6 There is no spacer on disc wheels.
- 5.7 Tighten lug nuts in prescribed crisscross / star pattern (see Figure 2); as a visual check, the same number of stud threads should show above the lug nuts after each tightening sequence.
- 5.8 Using a calibrated manual torque wrench tighten in the same crisscross / star pattern (Nut thread M22) to 450-500 lb.-ft. dry; do not over torque – it damages studs. For other thread torques, consult disc wheel manufacturer.
- 5.9 Be sure both tires have flow-through valve caps, or other type, as specified by owner.

### **NOTES:**

- 1. If inner or outer tire were run below stated pressure or flat, other inflated tire can be assumed to have performed double duty – and must be disassembled, inspected and actioned as required.
- 2. For wheel mounting steps of chassis originally equipped with **STUD PILOTED disc wheels**, consult wheel manufacturer for installation steps.

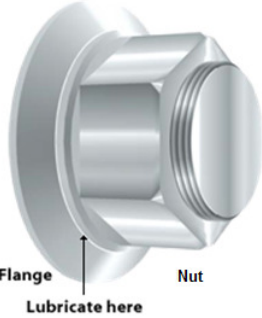
## **RELATED INFORMATION**

Leased chassis, when originally equipped with disc wheels, are frequently equipped with hub-piloted disc wheels. However, in case some chassis have stud piloted disc wheels, the following table and figures are presented to identify both types of disc wheels, to help avoid the accidental and incorrect use of nuts and wheels between the two hub types. The parts are NOT interchangeable and can cause failure and serious accident if mixed.

<p><b><u>Hub-Piloted Disc Wheel:</u></b></p> <p>Wheel has NON-chamfered and NON-beveled stud holes on inner and outer surfaces.</p>  <p style="text-align: center;"><b><u>Figure 3</u></b></p>	<p><b><u>Hub-Piloted Flange Nuts:</u></b></p> <p>Two piece lug nut with washer/flange integrated into the lug nut.</p> <p>Note: Consult wheel maker for recommended lug nuts, if changing from original wheels.</p>  <p style="text-align: center;"><b><u>Figure 4</u></b></p>
<p><b><u>Stud-Piloted Disc Wheel:</u></b></p> <p>Wheel has chamfered/beveled stud holes on inner and outer faces to accept ball-seated inner or outer lug nuts.</p>  <p style="text-align: center;"><b><u>Figure 5</u></b></p>	<p><b><u>Stud-Piloted Lug Nuts:</u></b></p> <p>Requires INNER and OUTER 'ball seated' lug nuts which fit into chamfered wheel holes.</p> <p>Install inner disc wheel with inner nut, then install outer disc wheel with outer nut tightened over inner nut.</p> <p>Note: Consult wheel maker for recommended lug nuts, if changing from original wheels.</p>   <p style="text-align: center;"><b><u>Figure 6: Inner Lug Nut</u></b>      <b><u>Figure 7: Outer Lug Nut</u></b></p>



**Exploded View – Spoke Dual Wheel / Demountable Rim System**

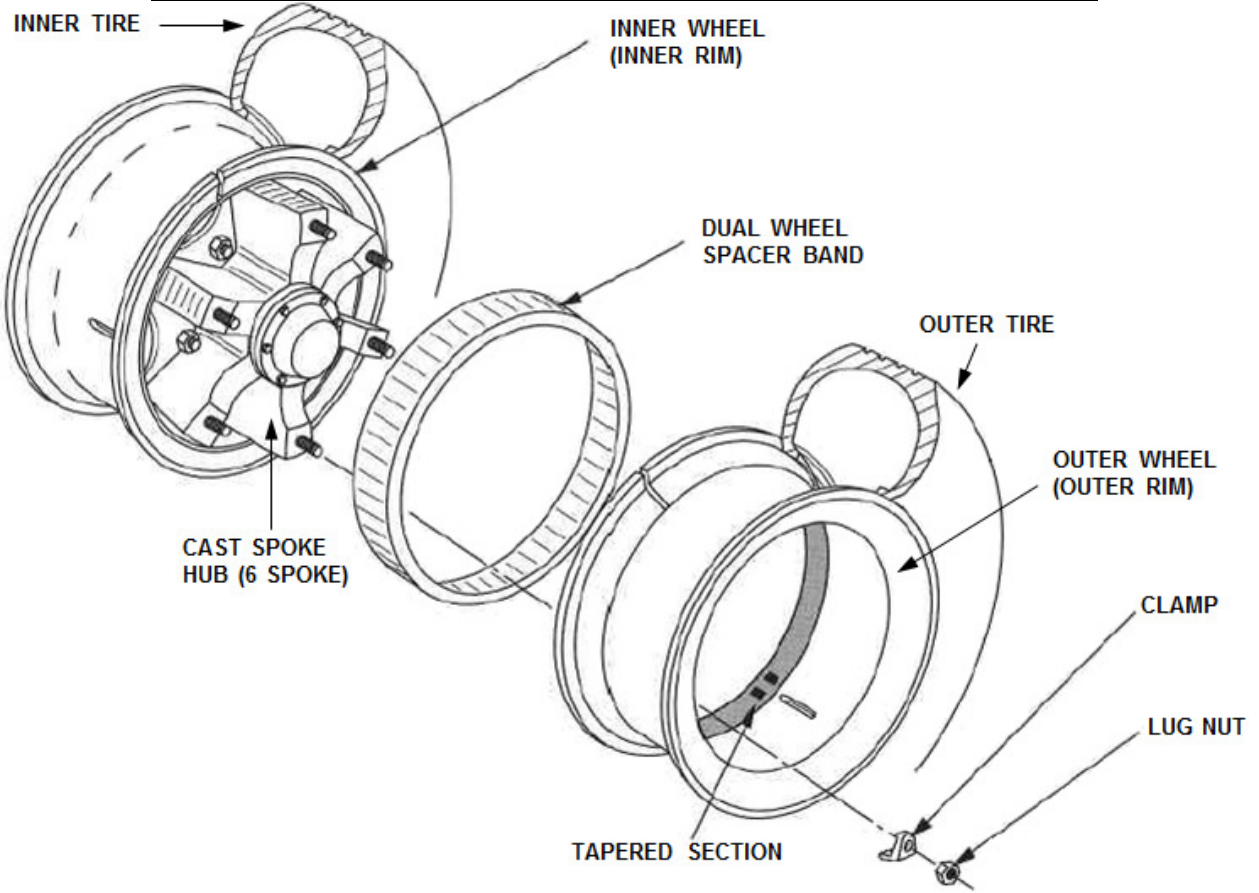

**Figure 8**

Cross-Section View of **HUB-PILOTED** Dual Disc Wheel mounting on hub:

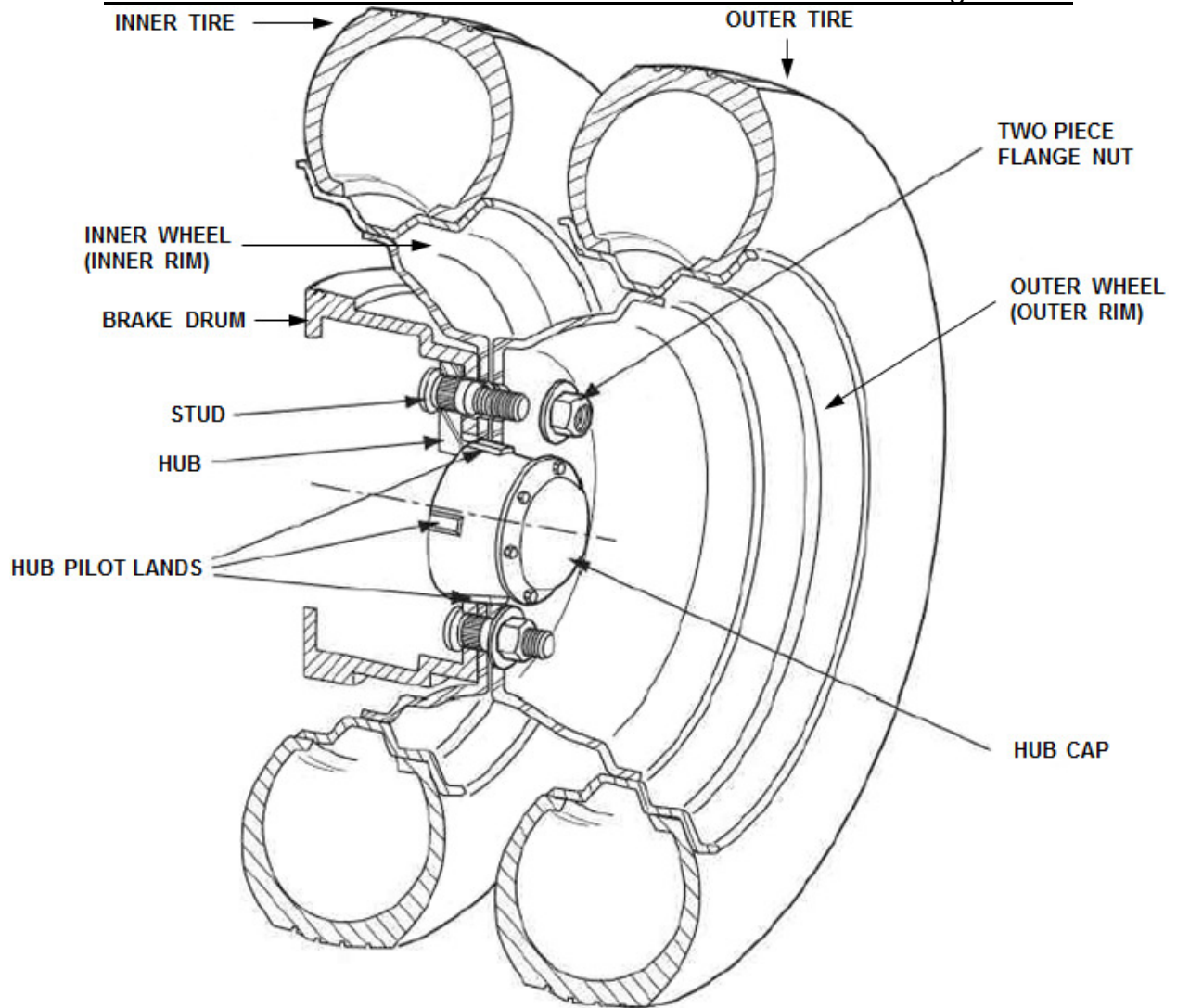

Figure 9

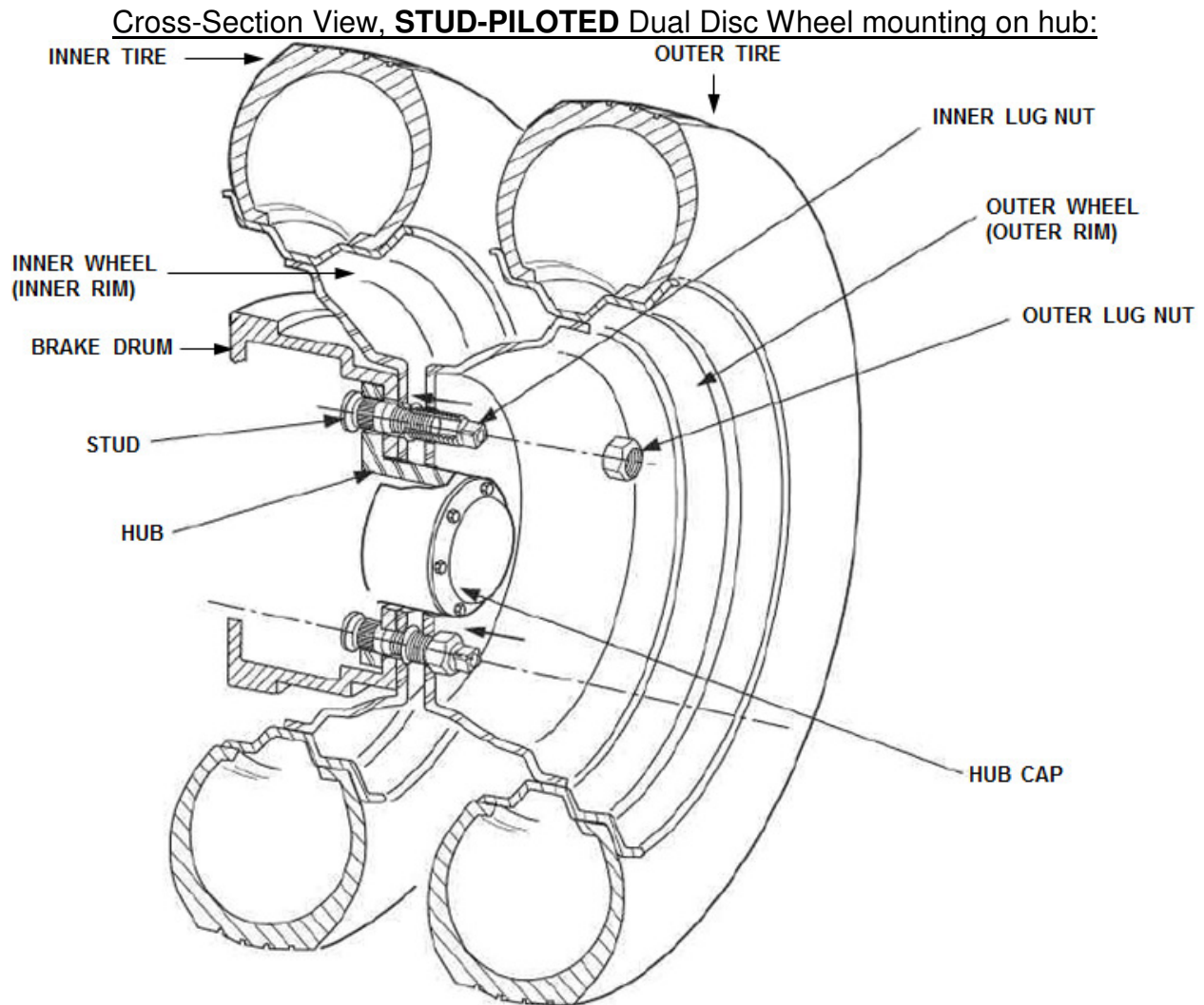

Figure 10

The material presented herein is extracted from OSHA, Accuride, the Tire Industry Association, and other on-line sources.

*Guidelines and procedures contained in this document have been accumulated from experienced equipment and service providers within the intermodal transportation industry, and are provided by IICL for informational purposes only. IICL does not assume any responsibility or liability pertaining to the procedures and guidance offered in this Manual, nor does IICL provide any warranties or guaranty that such guidelines and procedures comply with applicable state and federal regulatory requirements that may be applicable to the type of maintenance service discussed. Ultimately the responsibility to provide competent and safe maintenance and repair to intermodal chassis using properly qualified and trained mechanics and other maintenance employees is and remains the sole responsibility of the repair vendor.*

***1120 CONNECTICUT AVE NW, SUITE 440, WASHINGTON, DC 20036-3946 USA***  
***TELEPHONE: 202 223-9800 FAX: 202 223-9810***  
***WEBSITE: [www.iicl.org](http://www.iicl.org)***